

O-Rings & Kits
Wipers
Compounds
Custom Parts
Specialty Parts
Services
Rod Seals
Piston Seals

QUALITY | VALUE | SERVICE

Wear Guides

Wear Guides

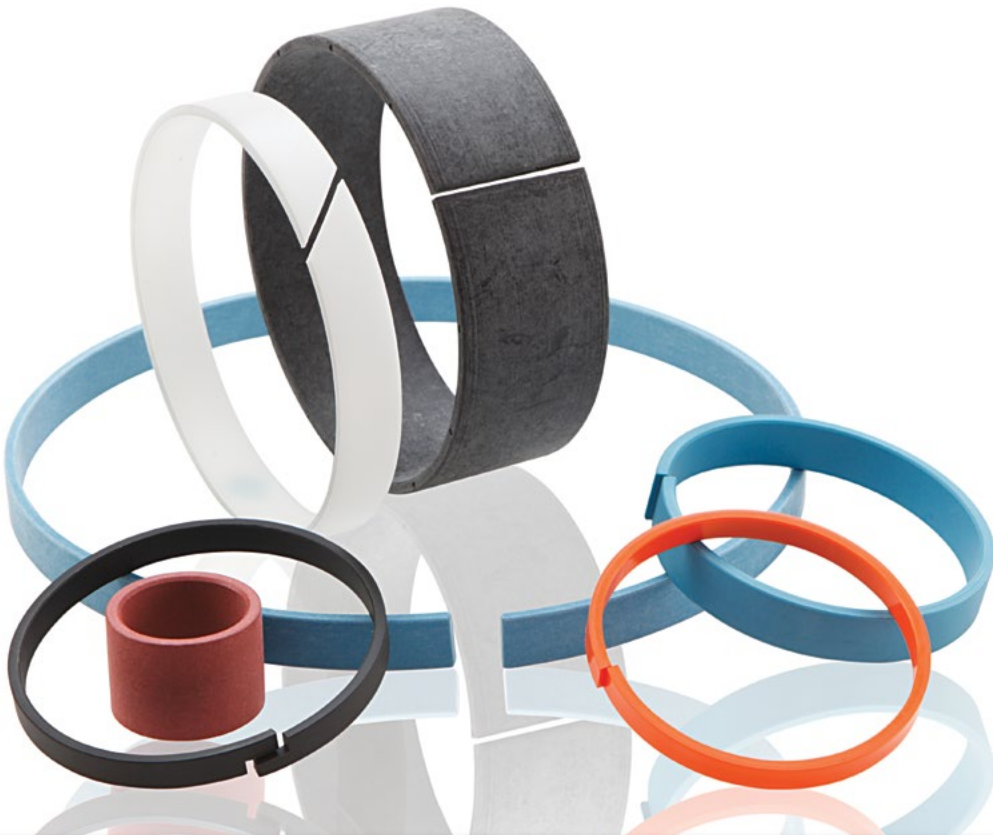

HIGH PERFORMANCE SEALS
An RT Dygert Company

Precision-close tolerance wear guides.



When it comes to moving parts in hydraulic and pneumatic cylinders, the highest quality wear guides are a must, preventing metal to metal contact and allowing continuous precision performance. Injection molding assures the greatest compressive strength. Imbedded nylon material helps protect hardware, prevent contamination and prohibit scoring and seal damage. Our wear guides are machined to the tightest tolerances and can be customized to your needs.

High Performance Seals has provided the industry's finest for over five decades, serving markets like hydraulics and pneumatics, oil and gas, robotics, chemical processing, food and beverage, lawn & garden, agricultural, mining, pumps and valves, wind energy and more. Our ISO 9001 Certification attests to our high standards.

For more information, quick quotations, expert consultation and responsive customer service call us at 877.796.0123 or visit www.highperformanceseals.com.

JOINT STYLES



BUTT-CUT WEAR GUIDE



ANGLE-CUT WEAR GUIDE



STEP-CUT WEAR GUIDE

RADIAL CROSS-SECTIONS

NOMINAL	ACTUAL	
1/16"	.062/.060	
3/32"	.093/.091	
1/8"	.125/.123	
3/16"	.187/.185	
NOMINAL	ACTUAL	
1,5mm	1,50/1,45	
2,0mm	2,00/1,95	
2,5mm	2,50/2,45	
3,0mm	3,00/2,95	
3,5mm	3,50/3,45	
4,0mm	4,00/3,95	
5,0mm	5,00/4,95	
6,0mm	6,00/5,95	

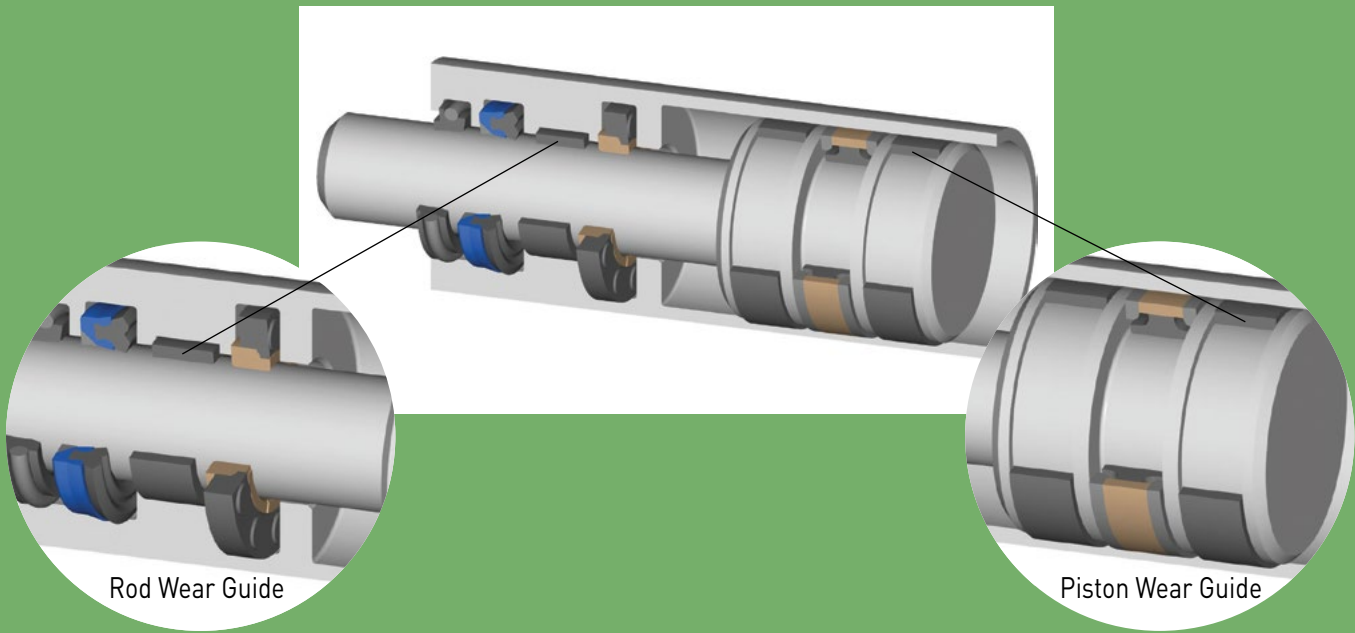

QUALITY | VALUE | SERVICE

MATERIALS

TYPE & DESCRIPTION	ADVANTAGES
Nylon, Glass-Fiber Reinforced	High compressive strength and load bearing with low wear properties
GFR Nylon & PTFE	High compressive strength with added lubricity
PTFE, Bronze filled	Low coefficient of friction, chemical resistance, no swell in moisture
Phenolic	High compressive strength at high temperatures, low friction
Acetal	No swell with good compressive strength, non-abrasive
PEEK, Carbon Graphite filled	High temperature limit, compressive strength, chemical resistance

RECOMMENDED C/S(IN) VS. DIAMETER

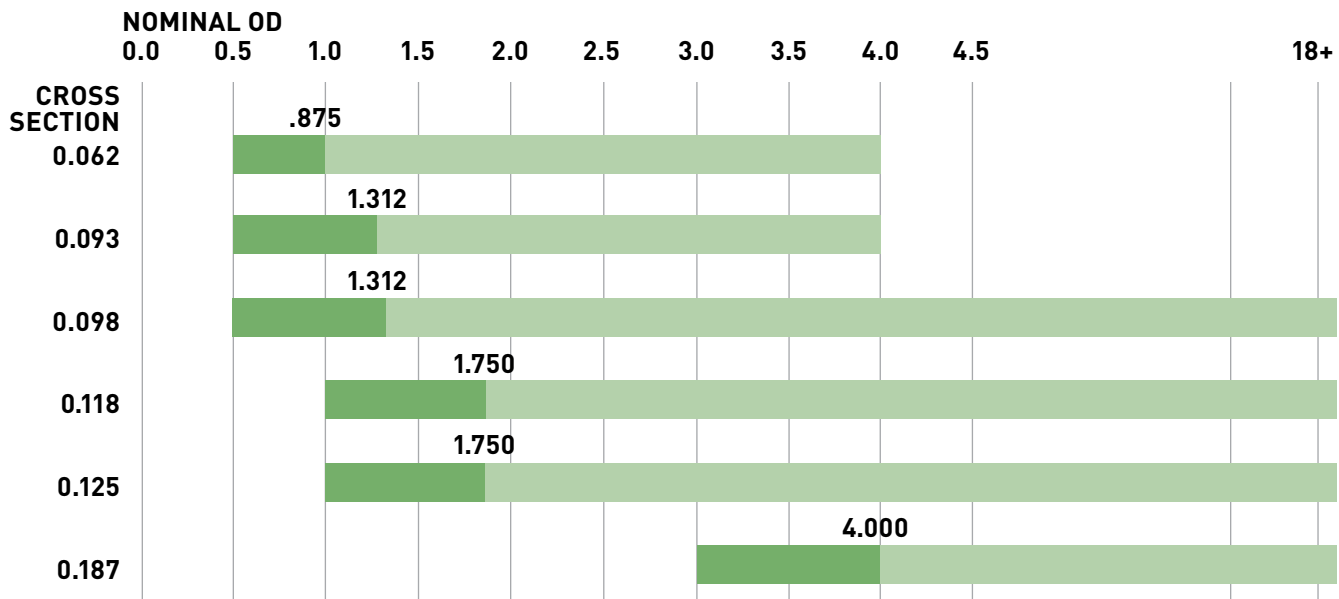

Light sections indicate installation for blind glands.

Wear Guides

sales@highperformanceseals.com • www.highperformanceseals.com

SEATTLE

3902 W. Valley Hwy N., Suite 200

Auburn, WA 98001

253.218.0123 PHONE

877.796.0123 TOLL FREE

253.218.0121 FAX

MINNEAPOLIS

12121 Nicollet Avenue S.

Burnsville, MN 55337

952.835.1700 PHONE

866.783.8883 TOLL FREE

952.835.1701 FAX

CHICAGO

2700 S. River Road, Suite 116

Des Plaines, IL 60018

847.675.1444 PHONE

800.423.9272 TOLL FREE

847.675.8889 FAX

© 2015, High Performance Seals, Inc.

LIMITED WARRANTY High Performance Seals ("Seller") warrants that its products ("Goods") will perform in accordance with their specifications; that the goods will be free from manufacturing defects for a period of twelve (12) months from the date of delivery of the goods to Buyer; and that the goods will be as specified by Buyer in the purchase order. Seller should have the right to elect to either refund the purchase price for any defective goods or replace any defective goods, provided that the goods were used in the manner for which they were manufactured. Seller does not warrant that the goods are fit for any particular purpose. Seller should have no obligation to refund the purchase price or replace goods that are rendered defective by a Buyer or a third party after they leave Seller's place of shipment.

LIMITED LIABILITY Seller's liability for its goods is limited to their terms set forth in Seller's express warranty set for above, in no event shall Seller's liability exceed the total purchase order price. Seller is not assuming any liability for any indirect, collateral, special, incidental or consequential losses or damages suffered by Buyer, or by any end-user or other third party, including but not limited to, lost profits, loss of business reputation and/or lost business opportunity, for any possible cause of action or claim arising out of or related to the goods sold to Buyer, even if Seller has been advised of the possibility of such loss or damage.

